

Rifton Stander Size 1

Thank you for choosing the Rifton Stander system.

This quick reference guide will help you with basic adjustments.

WARNING For more details and important safety information and warnings, please consult the product manual.



K222 Rev.00 © 2023 Rifton Equipment



Supine

Prone

Quick Reference Guide

CRITICAL SUPPORTS

SUPINE STANDING

1. Trunk Strap
2. Supine Hip Strap
3. Knee Strap
4. Sandals

PRONE STANDING

1. Trunk Strap
2. Pelvic Harness
3. Sandals

Initial stander configuration should be done by a qualified professional.

The Rifton stander system can be configured for prone or supine use. Review the available components to determine which your stander can be used for. Additional components can be obtained from www.rifton.com.

Straps have color coded tags. Use components with **GREEN** tags for supine positioning, and components with **BLUE** tags for prone positioning.

WARNING To avoid falls or strangulation, always ensure the correct straps and supports are used in each configuration. The infographic to the left shows the minimum straps and supports required for safe positioning in prone and supine standing.

These minimum supports are denoted throughout this guide by * for supine and * for prone.

Brakes

WARNING Product can tip over if used incorrectly. Always engage brakes during transfers and standing.

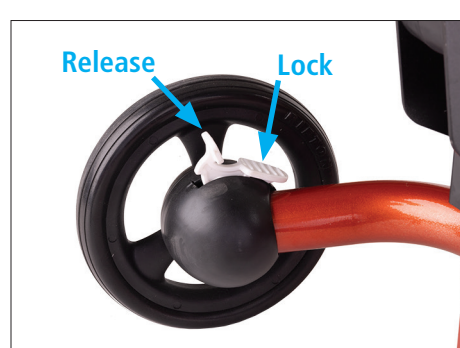

Height Adjustment

Grasp the handle on top of the column, and squeeze the white trigger to unlock and adjust the height.



Body support tilt

WARNING To prevent falls or other injury, ensure all straps are secure and knobs tight before tilting client to a standing position.

Grasp the handle firmly and squeeze the double trigger to adjust the body support angle.



*Upper trunk support SUPINE ONLY

Adjust the upper trunk support height by squeezing the two white triggers together and moving it to the desired location.



Headrest SUPINE ONLY

The headrest is the top section of the upper trunk support. Optional head laterals slide into the slots behind the headrest. Loosen the knob to adjust independently in height as well as width.



Hip abduction

Loosen the knob behind the user's hip to adjust abduction angle, and tighten in the desired position.

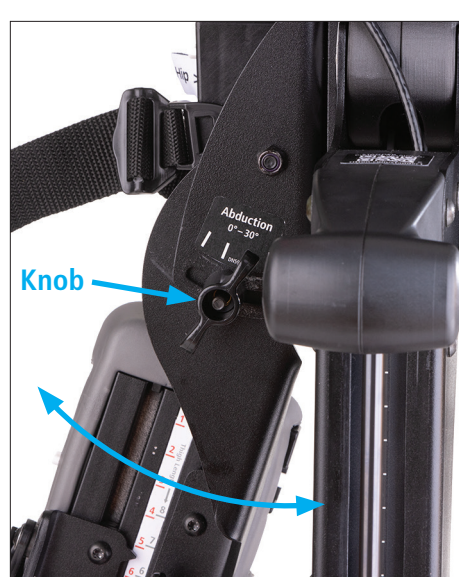

Thigh length

Loosen the inner knob (A) behind the thigh segment to adjust the thigh length.

TIP: Align the user's hips at the labeled hip length, then adjust the thigh length followed by the lower leg length. Align the center of the user's knee with the knee strap attachment points (B).

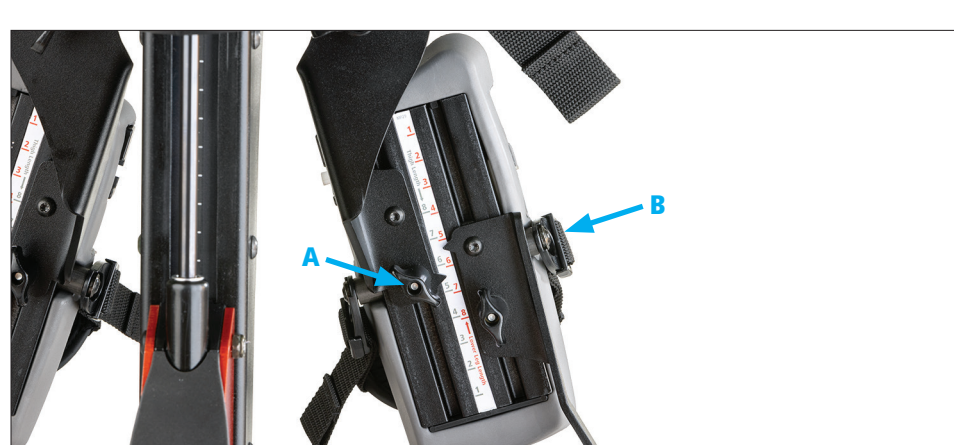

Lower leg length

Loosen the outer knob (C) behind the leg pad to adjust the lower leg length.

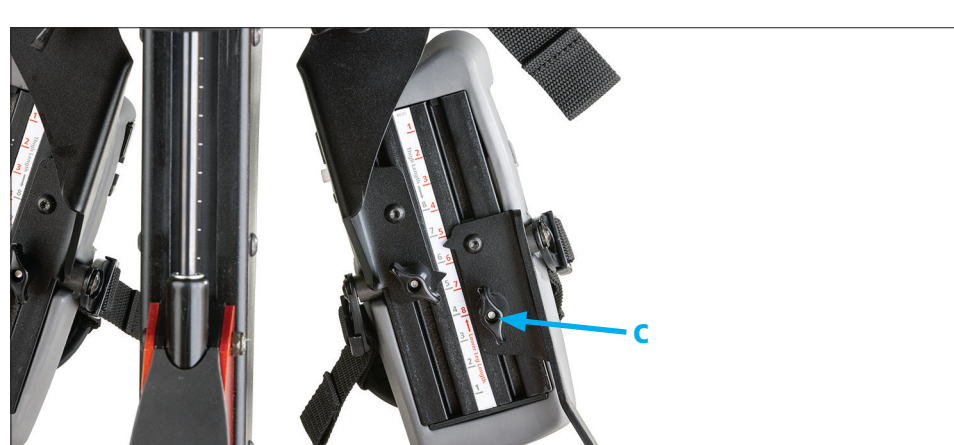

Ankle plantar flexion/dorsiflexion

Use the knob on the outer side of the ankle to adjust ankle plantar flexion/dorsiflexion.



**Sandals

Loosen the knob under the sandal to rotate the sandal or move it forward or backward.

The front and rear foot straps have magnetic buckles. Adjust the length of the heel cup using the velcro strap.

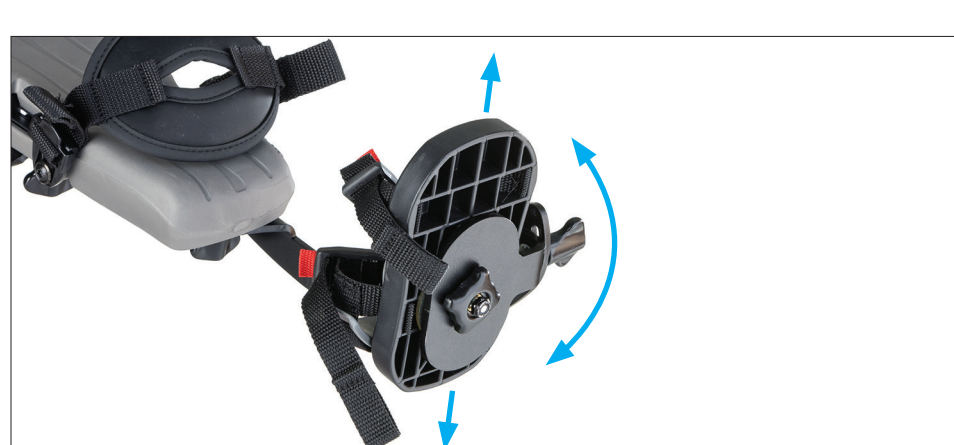

Tray

Loosen the knob that faces forward to adjust tray height.



Tray Height

Tray

Tray adjustments

Loosen all three knobs that face downward to rotate and position the tray. The knob under the center of the tray also allows some angle adjustment.



3 knobs for rotation

Tray Adjustments

Medial/Lateral thigh supports

Mount the medial/lateral thigh supports on the inside for medial support, or on the outside for lateral support. Adjust the width using the white trigger (A). The mounting bracket is off-center, so the pad has two possible height positions. Swap pads to change height position.

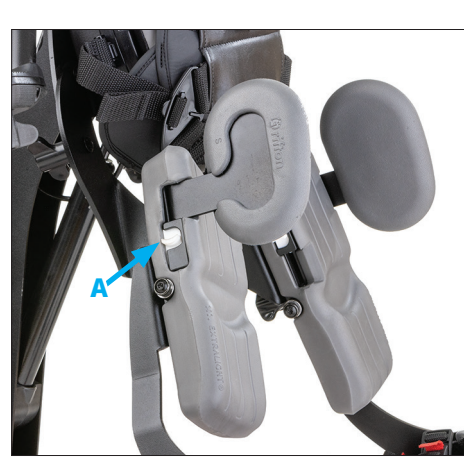

Thigh Medial / Laterals

Trunk laterals

Attach the laterals either at the level of the trunk or pelvis. Adjust width using trigger (B) on side of body support. Adjust height by loosening knob (C) on the outside and moving pad up or down. The pads swing away for transfers using the white button.

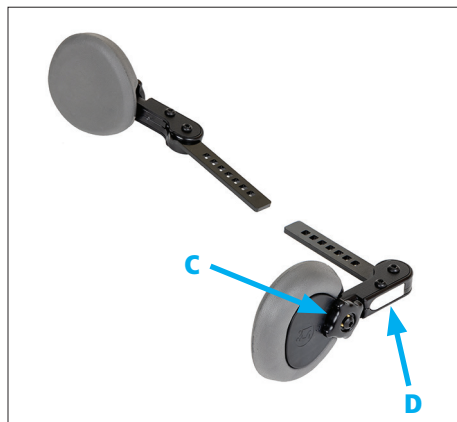

Trunk Laterals

All straps

To attach straps to the body support, insert the tip of the clip into the correct socket behind the body support and pull forward until it clicks. Pull the clip back and away from the pad to remove the strap.



All Straps

**Trunk strap/trunk rotation control strap

WARNING To prevent falls or other injury, all users should be secured with a trunk strap (or butterfly harness in supine configuration).

These straps may be used in prone or supine. The rotation control strap has a webbing loop that runs behind the pad. Close the padded strap snugly around the user, then close the buckle and tighten either side to control rotation of the trunk.



Trunk Strap

*Hip strap/hip rotation control strap

These straps are used in supine configuration. The rotation control strap has a webbing loop that runs behind the trunk support pad. Close the padded strap snugly around the user, then close the buckle and tighten either side to control rotation of the pelvis.



Supine Hip Strap

Butterfly harness

WARNING To prevent strangulation, always attach center safety strap and make sure all straps are snug before every use.

In supine standing a butterfly harness may be used in place of a trunk strap. Use all five attachment points.

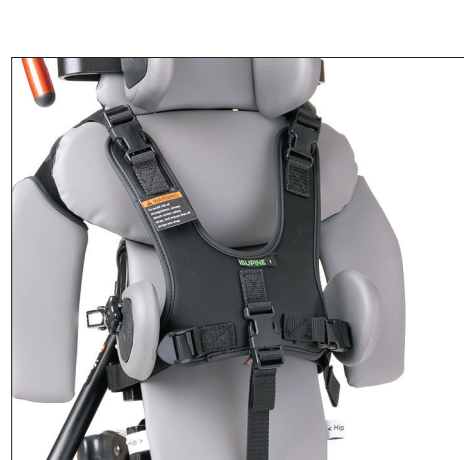

Butterfly Harness

*Knee straps

WARNING To prevent strangulation or other injury, in supine the user's knees MUST be secured with knee straps.

The knee straps clip onto the posts on either side of the knee. Pull the strap end to tighten and pull the plastic tab to loosen before unclipping the strap.



Knee Straps

*Pelvic harness

WARNING To prevent strangulation or other injury, in prone standing the prone pelvic harness MUST be used with all five attachment points secured.

Use the three buckles on the right side and center when transferring the user in and out. Tighten lower side straps first when positioning.



Pelvic Harness

Prone knee cuff

The Prone knee cuffs clip onto the posts on either side of the knee. Pull the strap end to tighten and pull the plastic tab to loosen before unclipping the strap.



Prone Knee Cuffs

Multi-Position Stander ONLY – Switching between PRONE and SUPINE

1. Remove upper trunk support

Squeeze the triggers on the back of the trunk support. Pull the upper trunk support up and rotate it back to remove it.



2. Switch tray direction

If the tray is used, loosen attachment knob (A), remove the tray and attach it facing the other direction. For use in prone, adjust the tray up, and the caregiver handle down and out of the way.



3. Switch to pelvic harness

Remove the supine hip strap. Install the pelvic harness by attaching all 5 attachment clips.



4. Remove knee straps

Optional prone knee cuffs may be added.



5. Rotate sandals 180°

Loosen the knob under the sandal (B), rotate it to the desired position, and tighten the knob.



1. Add upper trunk support

Insert the stampings into slots on top of body support. Squeeze triggers on back of body support to adjust the upper trunk support down to the desired position.

2. Switch tray direction

If the tray is used, loosen attachment knob (A), remove the tray and attach it facing the other direction.

3. Switch to supine hip strap

Remove the pelvic harness at all 5 attachment points. Install the supine hip strap (standard, or rotation control).

4. Add knee straps

Clip the knee straps onto the posts on either side of the knee.

5. Rotate sandals 180°

Loosen the knob under the sandal (B), rotate it to the desired position, and tighten the knob.

TO PRONE

TO SUPINE